

Polycom® Vortex® EF2241

Acoustic echo/noise canceller with automatic microphone/matrix mixer and phone add



Benefits

Industry leading audio quality – Design enhancements improve the audio experience for even the most demanding listening environments; support for the broadest range of microphones in the industry

Versatile telephone connection – With the Vortex EF2241, add standard (PSTN-based) calls or enjoy wideband audio performance with the Polycom SoundStation VTX 1000™ conference phone

Hear every word with Polycom's industry-leading acoustic echo and noise cancellation – Ensures the highest possible audio quality between sites with 20 kHz bandwidth, 270 ms tail length, more than 10 dB of room gain, and a convergence rate of over 40 dB per second on each mic/line channel

Integrated voice and video solution – May be linked with additional Vortex Installed Voice products including Vortex EF2201, Vortex EF2210, Vortex EF2211, Vortex EF2241 and Vortex EF2280; Polycom's SoundStation VTX 1000 wideband conference phone and Polycom's video conferencing systems including the VSX™ 7000 and 8000 product lines

Easy setup – Conference Composer™ and Polycom InstantDesigner™ software make configuration fast and simple

Easy to operate – Controllable via Crestron®, AMX® or other room control systems, RS-232, the Vortex EF-IR11 infrared controller, or from the unit's front panel; 16 factory presets and 32 user configurable presets allow quick selection of operating parameters

Adaptable to user requirements – User-programmable delays on all outputs, 5-band parametric EQ on all inputs and outputs, intelligent Automatic Gain Control, 256 macros, system diagnostics, and other tools ensure the best performance for all room conditions

Expand the audio capabilities of your installed conferencing facility and easily add phone calls.

The Vortex EF2241 enhances the productivity of conferencing and distance learning installations through industry-leading acoustic echo and noise cancellation, plus a DSP-based telephone interface - with support for up to four microphones.

Designed as a companion to Polycom's Vortex EF2280 model, as well as for standalone applications, the Vortex EF2241 automatically mixes four microphones and other audio, while canceling acoustic echoes and annoying background noise. The Vortex EF2241 includes an interface to the standard (PSTN) telephone network. It provides connections for multiple microphones and auxiliary inputs and includes a 10 Watt power amplifier for driving loudspeakers in the room.

The Vortex EF2241 supports four auxiliary audio sources and automatic mixing of up to four microphones per device. If more microphones or telephone interface channels are needed, additional Vortex units can be linked. Each microphone channel features industry-leading acoustic echo cancellation to prevent received signals from being retransmitted to their original locations. Neural network Automatic Gain Control (AGC) reacts only to valid speech patterns, bringing voices within desired levels. User-adjustable AGC controls for each channel, and settings for the five-band parametric EQ, are offered on all input and output channels.

The high-quality audio choice to access the power of Polycom unified collaborative communications solutions.

With the greatest breadth and depth of integrated video, voice, and Web solutions, only Polycom delivers the ultimate communications experience. Our market-leading conferencing and collaboration technologies, supported by world-class service, enable people and organizations to maximize their effectiveness and productivity. Add to that the most experience and proven best-practices in the industry, and it's clear why Polycom has become the smart choice for organizations seeking a strategic advantage in a real-time world.



Connect. Any Way You Want.

Polycom Vortex EF2241 Specifications

System Block Diagram and Rear Panel

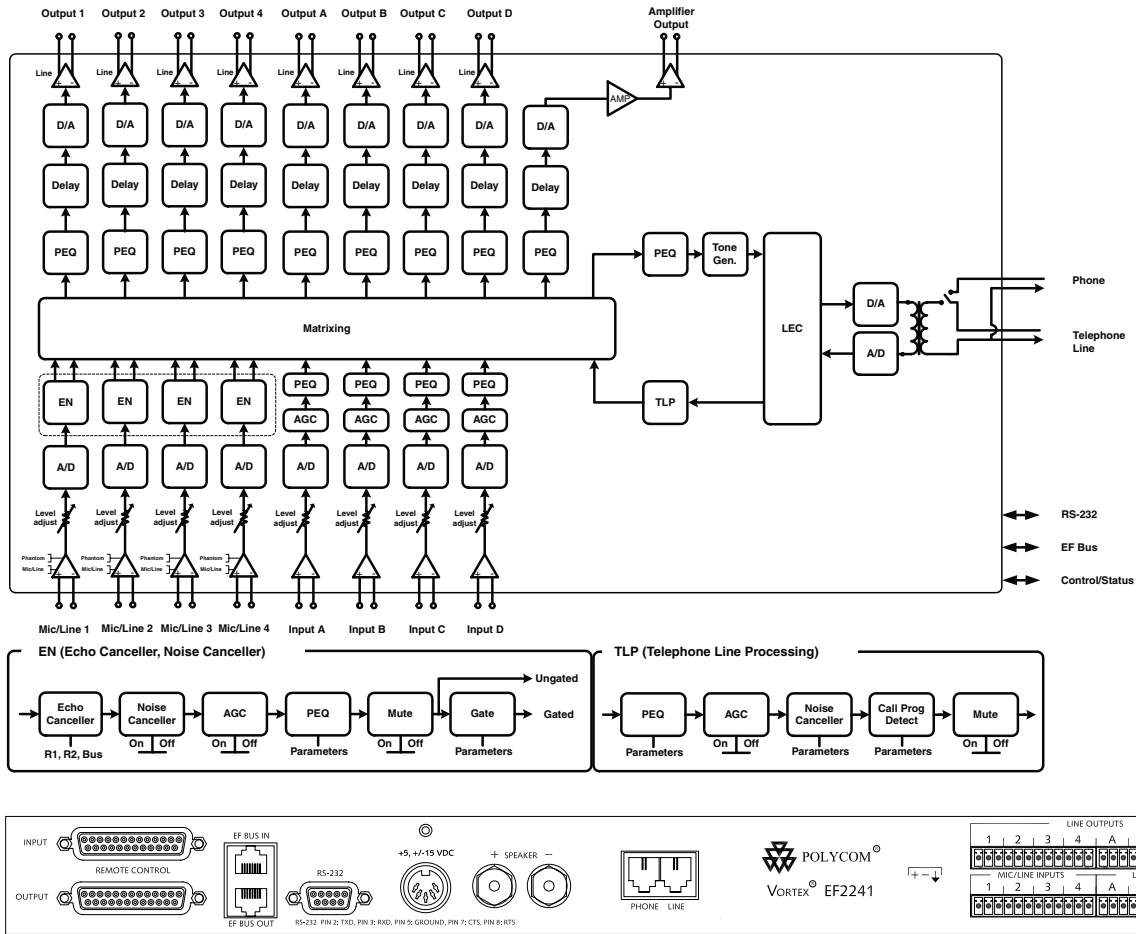

Dimensions

- 19" (483 mm) W x 9.6" (244 mm) L x 1.75" (45 mm) H (one rack unit)

Weight

- 4 lbs. (1.8 kg) dry, 5.5 lbs. (2.5 kg) shipping

Connectors

- RS-232: DB9F
- EF Bus In/Out: RJ45
- Control /Status: DB25F
- Telephone Line/Set: RJ11
- Audio: Mini (3.5mm) quick connect terminal blocks

Power

- External supply (provided)
- Input voltage of 110-240 VAC; 47-63 Hz; power consumption 30 W

Inputs

- Phantom power: 48 V DC, software selectable
- Analog input Gain: 0 to 30 dB Mic/line inputs in 1 dB steps, software adjustable
- Mic/Line switch gain: 33 dB
- Maximum input amplitude: +19 dBu, 1% THD + N
- Nominal level: 0 dBu (0.775 V rms)
- Equivalent input noise: <-124 dBu, 20 - 20,000 Hz
- Input Impedance: 10 kOhms
- Input EMI Filter: Pi filter on all audio inputs

Outputs

- Output Gain: -100 to 20 dBu in 1 dB steps, software adjustable
- Maximum output amplitude: +23 dBu, 1% THD + N
- Nominal output level: 0 dBu (0.775 V rms)
- Output impedance: 33 Ohm, each leg to ground (drives 600 Ohms)
- Output EMI Filter: Pi filter on all audio outputs

Amplifier

- Maximum Output Power: 8 Ohm, >10 W, 20 - 20,000 Hz, + 0.2 /- 0.5 dB
- Signal to noise ratio: 8 Ohm, >90 dB "A" weighted, 20 - 20,000 Hz
- Impedance: 4-16 Ohm

Telephone

- Input gain: -100 to +20 dB in 1 dB steps, software adjustable
- Nominal transmit level: 0 dBu in Vortex yields -15 to -17 dBm to phone (country code dependent)
- Off hook loop current: 16 mA (minimum) to 120 mA (maximum)
- Output gain: -100 to +20 dB in 1 dB steps, software adjustable
- Frequency response: 250-3300 Hz
- Dynamic range: >70 dB FS, 250-3300 Hz, "A" weighted

System*

- Frequency response: 20-20,000 Hz, + 0.2 /- 0.3 dB
- Idle channel noise: <-100 dB FS "A" weighted, 20 - 20,000 Hz, 0 dB gain
- Dynamic range: >100 dB FS "A" weighted, 20 - 20,000 Hz, 0 dB gain
- Linearity: 0 dB FS to -110 dB FS +/- 1 dB
- THD+N: < -90 dB FS
- Common Mode Rejection Ratio: <-61 dB, 20 - 20,000 Hz, no weighting
- Cross talk: <-104 dB, 20-20,000 Hz, channel-to-channel
- Latency: Mic/Line inputs to outputs: 13 ms, processing enabled
- Acoustic Echo Cancellation Span: 270 ms
- Total Cancellation: >65 dB
- Convergence Rate: 40 dB/second
- Noise cancellation: 0-15 dB, software selectable
- Operating Temperature: 0° - 40° C
- Control Inputs: Contact closure
- Status Outputs: 5 V, 20 mA each
- Line Echo cancellation (telephone hybrid)
 - Echo cancellation: 40 dB, total > 60 dB
 - Convergence Rate: 30 dB/second
 - Cancellation span: 32 ms

*Unless noted, all values are valid for all channels at line level

©2004 Polycom, Inc. All rights reserved.

Polycom, the Polycom logo, and Vortex are registered trademarks and SoundStation VTX 1000, VSX, Conference Composer and InstantDesigner are trademarks of Polycom, Inc. in the U.S. and various countries. All other trademarks are the property of their respective companies. Specifications subject to change without notice. For Architect's and Engineer's Specifications, please visit Polycom.com, or contact the Installed Voice Business Group at 1.770.641.4400.



Polycom Headquarters:

4750 Willow Road, Pleasanton, CA 94588 (T) 1.800.POLYCOM (765.9266) for North America only.
For North America, Latin America and Caribbean (T) +1.925.924.6000, (F) +1.925.924.6100

Polycom EMEA:

270 Bath Road, Slough, Berkshire SL1 4DX, (T) +44 (0)1753 723000, (F) +44 (0)1753 723010

Polycom Asia Pacific:

Polycom Hong Kong Ltd., Rm 1101 MassMutual Tower, 38 Gloucester Road, Wanchai, Hong Kong, (T) +852.2861.3113, (F) +852.2866.8028

Part No. 3726-82241-001 Rev. 10/04